

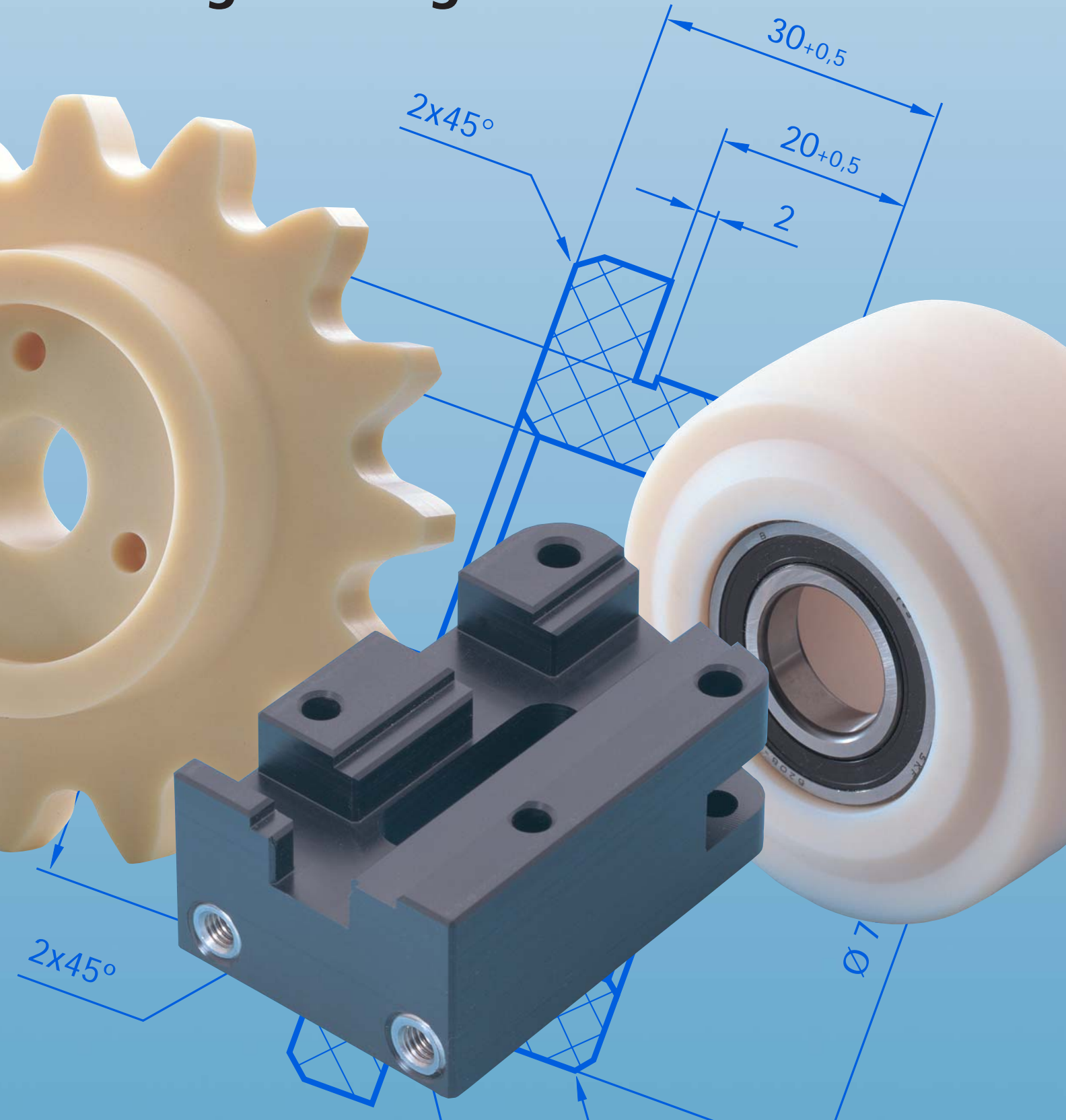

# Designing with engineering Plastics

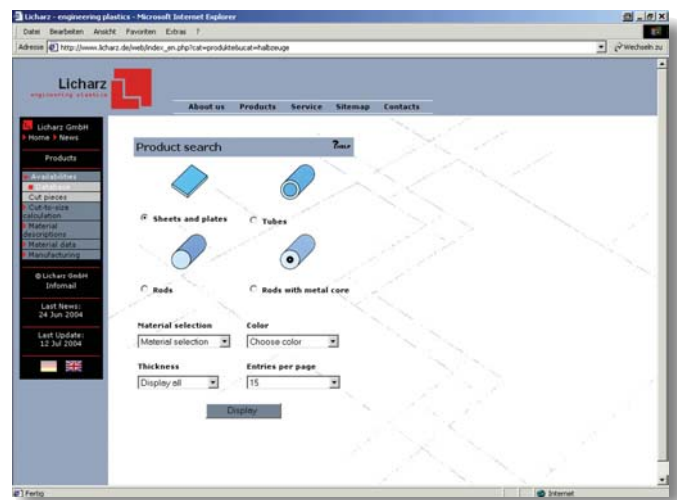

# Licharz on the web



# Plastic gear wheels



# Plastic gear wheels

## 1. Use of plastics as a gear material

Although thermoplastic gears are unsuitable for applications in high performance gears and for transmitting high power, they have opened up a broad field of application. The specific material properties allow use under conditions where even high quality metallic materials fail. For instance, plastic gears must be used if the following are the key requirements:

- Maintenance-free
- High wear resistance when used in a dry-running application
- Low noise
- Vibration damping
- Corrosion resistance
- Low mass moment of inertia through low weight
- Cost-effective manufacture

For a plastic to be able to satisfy these requirements, it is absolutely vital that the right material is chosen and that the design is carried out in a material-related manner.

### 1.1 Materials

Only a few thermoplastics are significant for the manufacture of gears. The plastics are described in detail in the previous chapters, so here we will only describe them in regard to tooth forming.

- **PA 6**  
Universal gear material for machine engineering; it is wear resistant and impact absorbing even when used in rough conditions, less suitable for small gear wheels with high dimensional requirements.
- **PA 66**  
Is more wear resistant than PA 6 apart from when it is used with very smooth mating components, more dimensionally stable than PA 6 as it absorbs less moisture, also less suitable for small gear wheels with high dimensional requirements.
- **PA 6 G**  
Essentially like PA 6 and PA 66, however, it is especially wear resistant due to its high degree of crystallinity.
- **Calaumid® 612 / 612 – Fe (PA 6/12 G)**  
Tough modified polyamide, suitable for use in areas with impact-like load peaks, wear resistance comparable to PA 6 G.
- **Calaumid® 1200 / 1200 – Fe (PA 12 G)**  
Tough-hard polyamide with relatively low tendency to absorb water, hence, better dimensional stability than other polyamides, especially suitable for use in areas with impact-like load peaks, excellent wear resistance.
- **Oilamid®**  
Self-lubricating properties due to oil in the plastic, hence, excellent for dry running applications and especially wear resistant.
- **POM – C**  
Because of its low moisture absorbing tendency it is especially suitable for small gears with high dimensional stability demands, not so loadable in dry running applications due to its hardness, however, if permanently lubricated, POM–C gears are more loadable than polyamide ones.

• **PE – UHMW**

Because of its low stability, it can only be used for gears that are not subjected to high loads, good damping properties and chemical resistance, hence mainly suitable for use in applications with mechanical vibration and in chemically aggressive environments.

## 1.2 Counterparts

Hardened steel is the most suitable counterpart regarding wear and utilisation of the load carrying capacity, as it ensures very good dissipation of friction heat. In regard to surface properties, the same applies as with friction bearings: the harder the steel the less wear on the wheel and pinions. As a guiding value, we recommend a maximum roughness depth of  $R_t = 8$  to  $10 \mu\text{m}$  both in lubricated operation and in dry running applications.

For gears that are not subject to heavy loads, it is possible to mate plastic/plastic. The surface roughnesses are insignificant for wear.

When choosing a material, it should be remembered that the driving pinions are always subjected to a higher level of wear. Consequently, the more wear resistant material should always be chosen for the pinions (→ pinion: steel, wheel: plastic or pinion: PA, wheel: POM).

## 1.3 Lubrication

The statements made in the chapter on »Friction bearings« regarding dry running and the use of lubricants also apply here. Basically it should be noted that installation lubrication considerably improves the service life and the running-in behaviour. Materials that are modified with a lubricant, such as Oilamid, have much longer service lives than all other plastics, even without lubrication. Continuous lubrication with oil leads to better heat dissipation and consequently to a longer life and higher levels of transmitted power.

When the component is lubricated with grease, the circumferential speed should not exceed 5 m/sec, as otherwise there is a danger that the grease will be cast off. Due to polyamide's tendency to absorb moisture, water lubrication is not recommended for polyamide components.

## 1.4 Noise development

Plastics in general have good damping properties. This considerably reduces noise on plastic gears compared to metal ones. The diagram opposite shows the sound intensity curves of gear mates steel/steel (a) and steel/plastic (b). It shows maximum differences of 9 dB. Hence, steel/steel is up to three times as loud as steel/plastic.

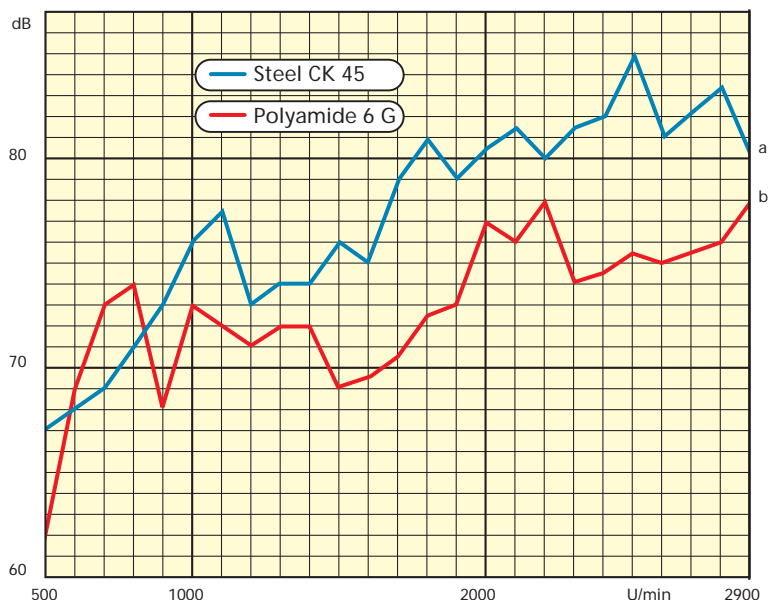

## 1.5 Manufacture

Plastic gears are manufactured with the same machining process as metal gears (usually shaping by the generating method and automatic hobbing).

As the cutting forces are very low, the profile can be manufactured in one cycle with high forward feed rates, which in turn reduces manufacturing costs.

When manufacturing with high forward feed rates, corrugated surfaces can be produced. At first these give an unfavourable impression. However, in dry running applications the faces of the

teeth are quickly smoothed after a short running-in period. In lubricated applications, the corrugated form acts as a lubrication pocket where the lubricant can collect – to the advantage of the gear. In other words, this corrugation is no reduction in quality.

Basically when machining plastic gears, depending on the module, qualities of 9 to 10 can be achieved. Regarding the tooth quality that can be achieved, it should be noted that the rolling tooth flanks of plastic gears easily fit one another. Therefore, greater tolerances are allowed than would be the case with metal gears. This especially applies to power transmitting pinions. For the grade that is exclusively related to tangential composite error  $F_i''$  and tangential tooth-to-tooth error  $f_i''$  this means that up to two grades more are permitted than for similar gears made from metal. The tooth play is increased by one to two grades compared to steel to compensate for temperature and moisture effects.

## 2. Design information

The following design information is intended to assist when dimensioning new gear components. Existing data should be used for gear designs that are in use and which have been tried and tested.

### 2.1 Width of the tooth face

For plastic gears there is basically no problem in extending their width to the same size as the diameter. Determining the smallest width is dependent upon the axial stability of the gear. No test results are available in regard to the connection between the life of the component and the width of the tooth face or regarding a determination of the optimum width of tooth face.

Practical experience has, however, shown that the width of the tooth face should be at least six to eight times the module.

For the mating components steel/plastic it is better to design the plastic gear slightly smaller than the steel pinion to make sure that the plastic gear is loaded across the entire width of the tooth face. A similar situation arises with the mating components plastic/plastic, where the dimensions of the gear on which the higher wear is expected should be slightly narrower. This prevents wear on the edges of the teeth, which could affect the running behaviour.

### 2.2 Module, angle of pressure and number of teeth

The load bearing capacity of plastic gears can be directly affected by the choice of module and angle of pressure. If, while maintaining the same peripheral force, the module/angle of pressure is increased, the root-strength of the teeth increases. However, compared to steel gears, the actual increase is less, as the effective contact ratio factor decreases and it is no longer possible for several teeth to engage simultaneously. A higher contact ratio factor, however, can be better for the load bearing capacity than increasing the root-strength of an individual tooth. We can derive the following connection from this (applies mainly to slow running or impact loaded gears):

- Preferably a small module for tough elastic thermoplastics (increase in the contact ratio factor, → several teeth engaged simultaneously)
- Preferably a large module for hard thermoplastics (increase in the root-strength of the teeth, as a higher contact ratio factor is not possible due to the inferior deformation behaviour)

In the case of gears with a high peripheral speed, attention must be paid that the movement is not affected by the effective contact ratio factor.

The angle of pressure for involute teeth is defined at 20°. Nevertheless, it can occasionally be necessary to change the angle of pressure (e.g. to decrease the number of teeth or reduce

running noise). Angles of pressure  $< 20^\circ$  lead to thinner and hence less loadable teeth with steep tooth profiles but low running noise.

Angles of pressure  $> 20^\circ$  produce sharper, thicker teeth with a greater root-strength and flatter profiles.

In regard to the number of teeth, it should be noted for higher peripheral speeds that the ratio between the number of teeth may not be an integer multiple. If this is the case, the same teeth always engage, which encourages wear.

## 2.3 Helical gearing

Experience has shown that helical plastic gears run quieter with a small helix angle than spur toothed types. However, the expected increase in the load bearing ability is smaller than is the case with steel gears. Although the length of the face contact line increases and the load is distributed among several teeth, the load is uneven and the teeth are deformed. This negates the advantage of helical gearing to a certain degree.

As with metal gears, helical toothed plastic gears are calculated via a spur toothed spare wheel.  $\beta \approx 10^\circ - 20^\circ$  is regarded as being a favourable helix angle.

## 2.4 Profile correction

Profile corrections are generally necessary when

- a gear pair has to be adapted to suit a specified axle base (positive or negative profile correction)
- the number of teeth is not reached and this causes undercut (positive profile correction)

In the application, attention should be paid that in the case of negative profile correction the undercut is not too great. This would result in a greatly minimised root-strength of the teeth, which could reduce the life and load bearing capacity of the gear.

Vice versa, in the case of positive profile correction, the thicker tooth root could cause a loss in the deformation capability and a subsequent reduction in the contact ratio factor.

## 2.5 Flank clearance and crest clearance

Because of the high thermal expansion factors of plastics when dimensioning gears, attention must be paid to the material-related fitting of the flank and crest clearances so that a minimum flank clearance is guaranteed. When plastic gears are used, it has proven practical to maintain a minimum flank clearance of  $\approx 0.04 \cdot \text{modulus}$ .

The built-in flank clearance is thus

$$S_e = S_{e0} + 2l \cdot \sin \alpha (k_\alpha \cdot k_F) \quad [\text{mm}]$$

where

$S_{e0}$  = minimum flank clearance in mm

$l$  = total distance consisting of plastic between the two rotational axes in mm

$\alpha$  = angle of pressure

$k_\alpha$  = coefficient of elongation

$k_F$  = correction factor for moisture absorption (to be used for polyamides, can be found in the chapter on »Friction bearings«)

For the inbuilt crest clearance, a measure of  $0.3 \cdot \text{module}$  has proven to be practical. This takes account of temperature fluctuations of up to  $\pm 20^\circ\text{C}$  and also makes adequate consideration for any inaccuracies in the toothed gears.

## 2.6 Power transmission

The feather key and groove type of connection that is generally used in machine engineering is also used for plastic gears. For a connection such as this, the flank of the key groove must be examined to ensure that it does not exceed the permissible surface pressure. The surface pressure is

$$p_F = \frac{M_d \cdot 10^3}{i \cdot r_m \cdot h \cdot b} \quad [\text{MPa}]$$

where

$M_d$  = transmitted torque in Nm

$i$  = number of groove flanks

$r_m$  = radius from the centre of the shaft to the centre of the bearing flank in mm

$h$  = height of the bearing flank in mm

$b$  = width of the bearing flank in mm

The value produced from the calculation is compared with Diagram 1 and may not exceed the maximum permissible values.

However, it should be noted that this value contains no safety factor for shock-type loads or safety reserves. Depending on the load, we recommend a safety factor of 1.5 to 4.

Because of the notch sensitivity of plastics when key grooves are being manufactured, attention should be paid that the edges are designed with a radius. However, this is generally not possible because the usual cutting tools and feather keys are sharp edged. When larger torques are being transmitted this can also cause deformation in the hub.

If the calculation of the flank pressure should produce high pressure values that are not permissible, or if hub deformation is feared, there are several possibilities of power transmission available.

One possibility is the non-positive connection of the wheel body with a steel insert. This is screwed to the wheel body. The diagram opposite shows one possible design solution.

For fixing the steel insert we recommend hexagon socket screws according to DIN 912, property class 8.8 or better in the following dimensions.

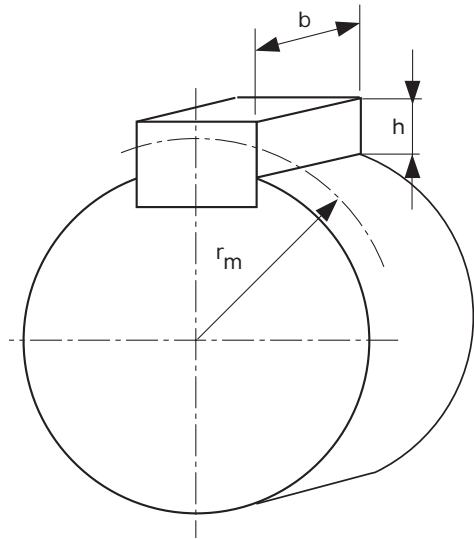
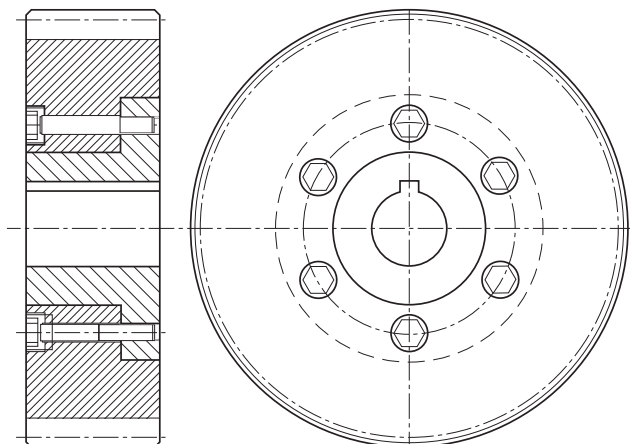
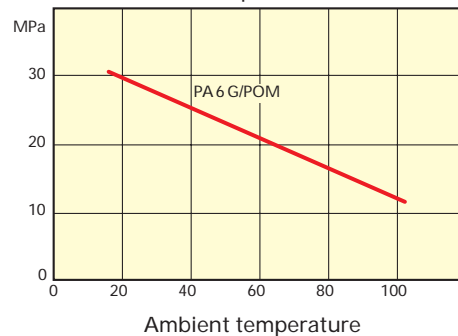

Diagram 1: Guiding value for permissible surface pressure



Tip diameter	Number of screws	Screw size
up to 100 mm	3	M 6
up to 200 mm	4	M 8
above 200 mm	6	M 8 / M 10

For gears with relatively thin walls, it is advisable to use hexagon socket screws with a low head according to DIN 6912, property class 8.8 or better.

One alternative to the use of a screwed steel fitting is to design the gears in Calaumid 612 Fe or Calaumid 1200 Fe. The metallic core which is connected to the plastic both in a form-fit and non-positive manner enables the shaft-hub connection to be calculated and dimensioned like a metallic component as usual. The form-fit and non-positive connection between the plastic casing and the metallic core is created with a knurl.

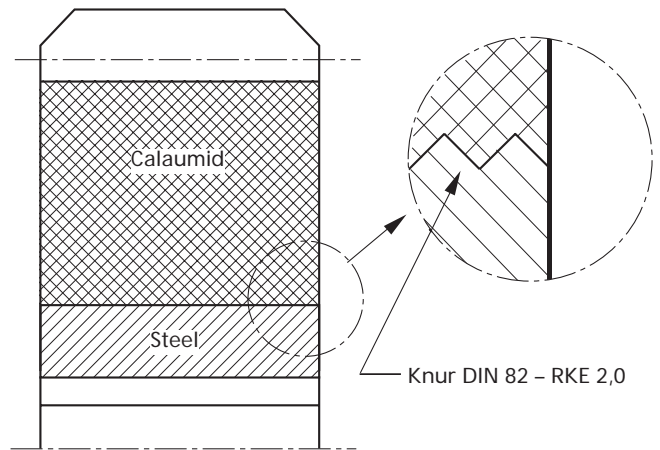

### 3. Calculating thermoplastic gears wheels

The reasons for the premature breakdown of thermoplastic gears are generally the same damage aspects and principles that occur in metallic gears. This is why the calculation of plastic gears does not differ in principle from the known methods. The only difference is that the material-specific properties of plastics are included in the calculations in the form of correction factors.

#### 3.1 Torque $M_d$ , peripheral force $F_U$ and peripheral speed $v$

The torque is

$$M_d = 9550 \cdot \frac{P}{n} \quad [\text{Nm}]$$

where

$P$  = power in kW

$n$  = speed in  $\text{min}^{-1}$

The peripheral force is

$$F_U = 2 \cdot 10^3 \cdot \frac{M_d}{d_0} \quad [\text{N}]$$

where

$M_d$  = torque in Nm

$d_0$  = reference diameter in mm

The peripheral speed is calculated as

$$v = \frac{d_0 \cdot \pi \cdot n}{60 \cdot 10^3} \quad [\text{m/s}]$$

where

$d_0$  = reference diameter in mm

$n$  = speed in  $\text{min}^{-1}$

#### 3.2 Tooth body temperature $\vartheta_Z$ and tooth flank temperature $\vartheta_F$ in continuous operation

As with all designs made from thermoplastic materials, temperature also plays a major role for gears in regard to the load bearing capacity of the component. A distinction is made between the tooth body temperature  $\vartheta_Z$  and the tooth flank temperature  $\vartheta_F$ .

The tooth body temperature is responsible for the permissible tooth root loading and tooth deformation, whereas the tooth flank temperature is used to roughly estimate the level of wear.

However, it is very difficult to determine these two temperatures accurately, as on a rotating gear wheel the heat transmission coefficient can only be estimated roughly. Consequently, any arithmetical determination of the temperatures is liable to have a certain amount of error. In particular, when the tooth flank temperature is being calculated, quite often high values are produced which, in some cases, are even above the melting temperatures of the plastics. However, in practice no melting of the tooth profile has been observed. Nevertheless, the values can be regarded as characteristic and comparison temperature values.

It can be assumed that the excessive calculated values would guarantee a design which is on the safe side in any case.

For the thermal calculation of the gears, the friction heat, the heat dissipated from the gear wheel in the gear room and the heat that is dissipated from the gear room to the outside must be considered.

Under these conditions, we get the following:

$$\vartheta_{1,2} = \vartheta_U + P \cdot \mu \cdot 136 \cdot \frac{i + 1}{z_{1,2} + 5i} \cdot \left[ \frac{k_2 \cdot 17100}{b \cdot z_{1,2} \cdot (v \cdot m)^{\frac{3}{4}}} + 7,33 \cdot \frac{k_3}{A} \right] \quad [^{\circ}\text{C}]$$

where

Index 1 for the pinion

Index 2 for the wheel

$\vartheta_U$  = ambient temperature in  $^{\circ}\text{C}$

P = power in kW

$\mu$  = coefficient of friction

z = teeth

i = transmission ratio  $z_1/z_2$  with

$z_1$  = number of teeth in pinion

b = width of the tooth face in mm

v = peripheral speed in m/sec

m = module in mm

A = surface of the gear casing in  $\text{m}^2$

$k_2$  = material-related factor

$k_3$  = gear-related factor in  $\text{m}^2 \text{K/W}$

For factor  $k_2$  the following must be included depending on the temperature to be calculated:

Calculation of flank temperature:

$k_2 = 7$  for mating components steel/plastic

$k_2 = 10$  for mating components plastic/plastic

$k_2 = 0$  in the case of oil lubrication

$k_2 = 0$  at  $v \leq 1$  m/sec

Calculation of root temperature:

$k_2 = 1.0$  for mating components steel/plastic

$k_2 = 2.4$  for mating components plastic/plastic

$k_2 = 0$  in the case of oil lubrication

$k_2 = 0$  at  $v \leq 1$  m/sec

For factor  $k_3$  and the coefficient of friction  $\mu$ , the following must be included independent of the temperature to be calculated:

$k_3 = 0$  for completely open gear  $\text{m}^2 \text{K/W}$

$k_3 = 0.043$  to  $0.129$  for partially open gear in  $\text{m}^2 \text{K/W}$

$k_3 = 0.172$  for closed gear in  $\text{m}^2 \text{K/W}$

$\mu = 0.04$  for gears with permanent lubrication

$\mu = 0.07$  for gears with oil mist lubrication

$\mu = 0.09$  for gears with assembly lubrication

$\mu = 0.2$  PA/steel

$\mu = 0.4$  PA/PA

$\mu = 0.25$  PA/POM

$\mu = 0.18$  POM/Stahl

$\mu = 0.2$  POM/POM

### 3.2.1 Tooth body temperature $\vartheta_z$ and tooth flank temperature $\vartheta_f$ in intermittent operation

Analogous to friction bearings, because of the lower amount of heat caused by friction, gears in intermittent operation are increasingly loadable the lower the duty cycle. The relative duty cycle ED is considered in the equation in section 3.2 by introducing a correction factor f.

The relative duty cycle is defined as the ratio between the load duration t and the overall cycle time

T as a percentage.

$$ED = \frac{t}{T} \cdot 100 \quad [\%]$$

where

t = total of all load times within the cycle time T in min

T = cycle time in min

For thermoplastic gears, the overall cycle time is defined as  $T = 75$  min. The total of all individual load times occurring within this 75 min forms the load duration  $t$ .

With the value that has been calculated in this manner it is now possible to determine the correction factor  $f$  from Diagram 2. Attention should be paid that each load duration which exceeds 75 min (regardless of whether this is only once) is evaluated as a continuous load.

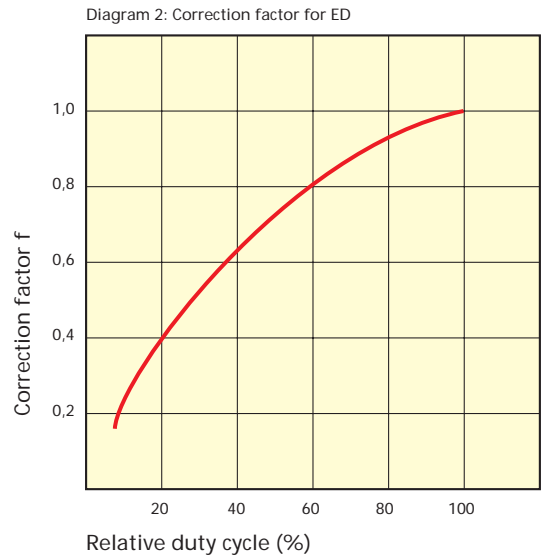

Taking account of the correction factor, the tooth flank temperature and tooth body temperature is

$$\vartheta_{1,2} = \vartheta_U + P \cdot f \cdot \mu \cdot 136 \cdot \frac{i+1}{z_{1,2} + 5i} \cdot \left[ \frac{k_2 \cdot 17100}{b \cdot z_{1,2} \cdot (v \cdot m)^{\frac{3}{4}}} + 7,33 \cdot \frac{k_3}{A} \right] \quad [^{\circ}\text{C}]$$

The values given in section 3.2 can be used for the factors  $k_2$ ,  $k_3$  and the coefficient of friction  $\mu$ .

### 3.3 Calculating the root strength of teeth

If the tooth root stress  $\sigma_F$  exceeds the permissible stress  $\sigma_{Fper}$  under loading, it must be assumed that the teeth will break. For this reason the tooth root stress must be calculated and compared with the permissible values. If the pinion and gear are constructed from plastic, the calculations must be carried out separately for each of them.

The tooth root stress is

$$\sigma_F = \frac{F_U}{b \cdot m} \cdot K_B \cdot Y_F \cdot Y_\beta \cdot Y_\epsilon \quad [\text{MPa}]$$

where

$F_U$  = peripheral force in N

$b$  = gear width in mm (where the width of the pinion and gear differ: use the smaller width +  $m$  as a calculation value for the wider gear)

$m$  = module in mm

$K_B$  = operating factor for different types of drive operation, from Table 2

$Y_F$  = tooth shape factor from Diagram 3

$Y_\beta$  = helix factor to take account of the increase in load bearing capacity in helical gearing, as this is the case with plastic gears, this value is to be set as 1.0

$Y_\epsilon$  = contact ratio factor from Table 1, where  $Y_\epsilon = 1/\epsilon_\alpha$  und  $\epsilon_\alpha = \epsilon_{\alpha z1} + \epsilon_{\alpha z2}$

Table 1: Partial transverse contact ratio for gears without profile correction

<b>z</b>	<b>14</b>	<b>15</b>	<b>16</b>	<b>17</b>	<b>18</b>	<b>19</b>	<b>20</b>	<b>21</b>	<b>22</b>	<b>23</b>	<b>24</b>
$\epsilon_{\alpha z}$	0,731	0,740	0,749	0,757	0,765	0,771	0,778	0,784	0,790	0,796	0,801
<b>z</b>	<b>25</b>	<b>26</b>	<b>27</b>	<b>28</b>	<b>29</b>	<b>30</b>	<b>31</b>	<b>32</b>	<b>33</b>	<b>34</b>	<b>35</b>
$\epsilon_{\alpha z}$	0,805	0,810	0,815	0,819	0,822	0,827	0,830	0,833	0,837	0,840	0,843
<b>z</b>	<b>36</b>	<b>37</b>	<b>38</b>	<b>39</b>	<b>40</b>	<b>41</b>	<b>42</b>	<b>43</b>	<b>44</b>	<b>45</b>	<b>46</b>
$\epsilon_{\alpha z}$	0,846	0,849	0,851	0,854	0,857	0,859	0,861	0,863	0,866	0,868	0,870
<b>z</b>	<b>47</b>	<b>48</b>	<b>49</b>	<b>50</b>	<b>51</b>	<b>52</b>	<b>53</b>	<b>54</b>	<b>55</b>	<b>56</b>	<b>57</b>
$\epsilon_{\alpha z}$	0,872	0,873	0,875	0,877	0,879	0,880	0,882	0,883	0,885	0,887	0,888
<b>z</b>	<b>58</b>	<b>59</b>	<b>60</b>	<b>61</b>	<b>62</b>	<b>63</b>	<b>64</b>	<b>65</b>	<b>66</b>	<b>67</b>	<b>68</b>
$\epsilon_{\alpha z}$	0,889	0,891	0,892	0,893	0,895	0,896	0,897	0,898	0,899	0,900	0,901
<b>z</b>	<b>69</b>	<b>70</b>	<b>71</b>	<b>72</b>	<b>73</b>	<b>74</b>	<b>75</b>	<b>76</b>	<b>77</b>	<b>78</b>	<b>79</b>
$\epsilon_{\alpha z}$	0,903	0,903	0,904	0,906	0,906	0,907	0,909	0,909	0,910	0,911	0,912
<b>z</b>	<b>80</b>	<b>81</b>	<b>82</b>	<b>83</b>	<b>84</b>	<b>85</b>	<b>86</b>	<b>87</b>	<b>88</b>	<b>89</b>	<b>90</b>
$\epsilon_{\alpha z}$	0,913	0,913	0,914	0,915	0,916	0,917	0,917	0,918	0,919	0,919	0,920
<b>z</b>	<b>91</b>	<b>92</b>	<b>93</b>	<b>94</b>	<b>95</b>	<b>96</b>	<b>97</b>	<b>98</b>	<b>99</b>	<b>100</b>	<b>101</b>
$\epsilon_{\alpha z}$	0,920	0,921	0,922	0,922	0,923	0,924	0,924	0,925	0,925	0,926	0,927

Table 2: Operating factor  $K_B$

Mode of operation of the driving machine	Mode of operation of the driven machine			
	Even	Moderate impact	Average impact	Strong impact
Even	1,0	1,25	1,5	1,75
Moderate impact	1,1	1,35	1,6	1,85
Average impact	1,25	1,5	1,75	2,0
Strong impact	1,5	1,75	2,0	2,25

Diagram 3: Tooth formation factor  $Y_F$  as a function of the number of teeth

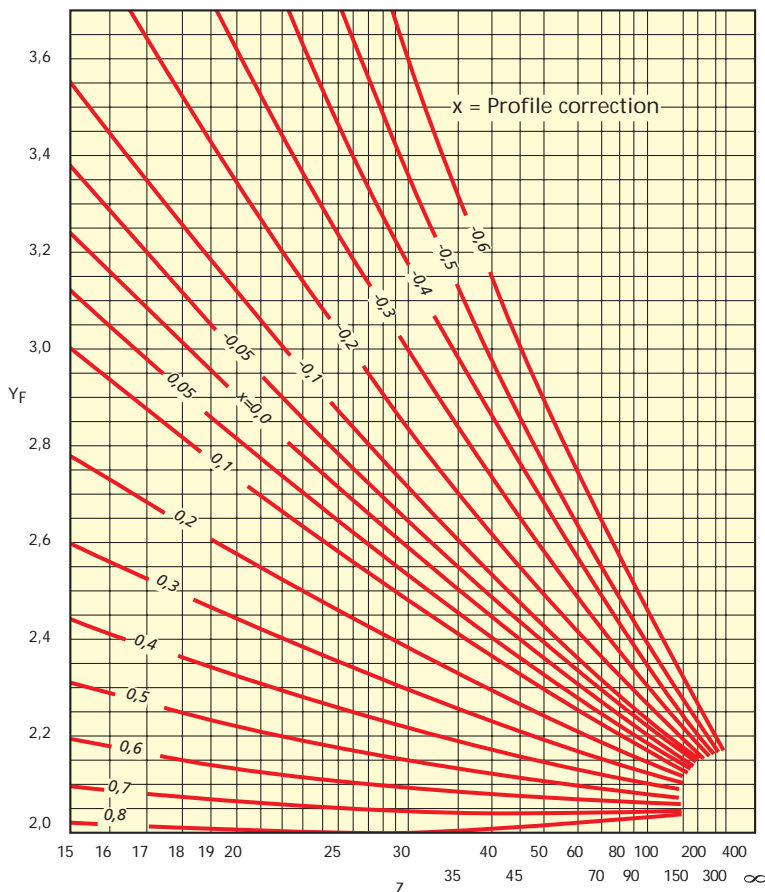

In the case of profile corrected toothed gears the factor  $Y_\epsilon$  must be adjusted accordingly. The following applies:

$$\epsilon_\alpha = \frac{z_1}{2 \cdot \pi} \cdot (\tan \alpha_{E1} - \tan \alpha_{A1}) \quad \text{and} \quad \tan \alpha_{A1} = \tan \alpha_{tw} \cdot \left( 1 + \frac{z_2}{z_1} \right) - \frac{z_2}{z_1} \tan \alpha_{A2}$$

The value  $\tan \alpha_{E1}$  is dependent on the correction value

$$D_1 = \frac{d_{K1}}{d_{G2}}$$

where

$d_{K1}$  = outside diameter of pinion  
 $d_{G2}$  = base diameter of large wheel

The value  $\tan \alpha_{A2}$  is dependent on the correction value

$$D_2 = \frac{d_{K1}}{d_{G2}}$$

where

$d_{K2}$  = outside diameter of large wheel  
 $d_{G1}$  = base diameter of pinion

The values for  $\tan \alpha_{E1}$  and  $\tan \alpha_{A2}$  can be taken from Diagram 5. The effective pressure angles  $\alpha_{tw}$  and  $\tan \alpha_{tw}$  are calculated from the profile correction  $x_{1,2}$  and the number of teeth  $z_{1,2}$  where Index 1 stands for the pinion and Index 2 for the large gear. The effective pressure angles for spur gears are shown in Diagram 4.

Diagram 4: Effective pressure angle  $\alpha_{tw}$ ,  $\tan \alpha_{tw}$

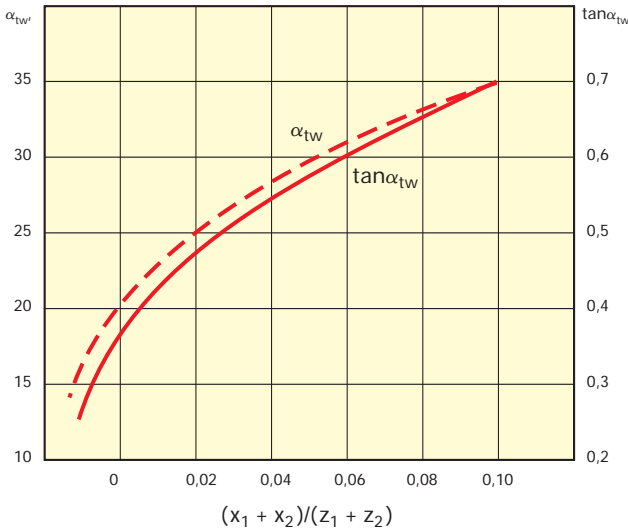
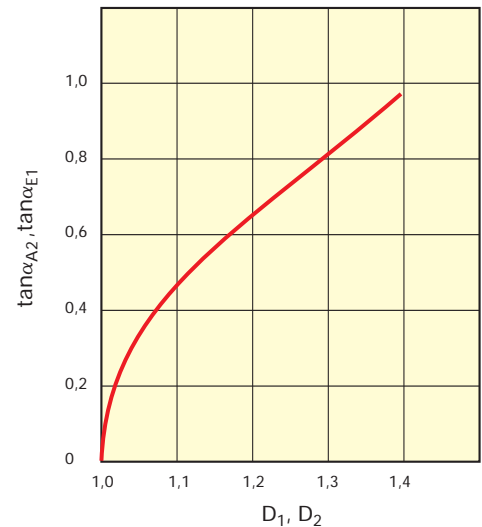

Diagram 5: Correction diagram for transverse contact ratio



### 3.4 Calculating tooth profile strength

Excessive pressure on the tooth profile can cause pitting or excessive wear. The wear is particularly obvious in the root and crest of the tooth, which changes the tooth formation and consequently leads to uneven transmission of motion.

In order to prevent premature failure due to excessive wear or pitting, the tooth flank pressure  $\sigma_H$  must be determined. The pressure occurring on the tooth flank is

$$\sigma_H = \sqrt{\frac{F_U \cdot (z_1 + z_2)}{b \cdot d_0 \cdot z_2}} \cdot K_B \cdot Z_\epsilon \cdot Z_H \cdot Z_M \quad [\text{MPa}]$$

where

$F_U$  = peripheral force in N  
 $z_1$  = number of teeth in pinion  
 $z_2$  = number of teeth in large gear  
 $b$  = gear width in mm (where the width of the pinion and gear differ: use the smaller width + m as a calculation value for the wider gear)

$d_0$  = reference diameter in mm  
 $K_B$  = operating factor for different types of drive operation, from Table 2  
 $Z_\epsilon$  = contact ratio factor  
 $Z_H$  = zone factor  
 $Z_M$  = material factor

The contact ratio of several teeth acts like a widening of the tooth. This apparent widening is taken account of with the contact ratio factor  $Z_\epsilon$  and equated for spur and helical gears.

The contact ratio factor becomes

$$Z_\epsilon = \sqrt{\frac{4 - (\epsilon_{\alpha z1} + \epsilon_{\alpha z2})}{3}}$$

where

$\epsilon_{\alpha z1}$  = partial transverse contact ratio of pinion  
from Table 1

$\epsilon_{\alpha z2}$  = partial transverse contact ratio of large wheel  
from Table 1

The tooth formation factor  $Z_H$  takes account of the tooth flank distortion. In the case of non-profile corrected spur teeth with an angle of pressure of  $\alpha = 20^\circ$  the zone factor can be approximated with  $Z_H = 1.76$ . For profile corrected spur teeth  $Z_H$  can be taken from the diagram opposite.

For angles of pressure other than  $20^\circ$  the following applies:

$$Z_H = \frac{1}{\cos\alpha} \cdot \sqrt{\frac{1}{\tan\alpha_{tw}}}$$

where

$\alpha$  = normal angle of pressure

$\tan\alpha_{tw}$  = effective pressure angle from Diagram 4

The elasticity of the plastic and consequently the effective contact surface of the tooth profile are considered with the material factor  $Z_M$ .

It can be said with sufficient accuracy that

$$Z_M = \sqrt{0,38 \cdot E'} \quad \text{and} \quad E' = \frac{E_1 \cdot E_2}{E_1 + E_2}$$

where

$E_1$  = dynamic modulus of elasticity of the pinion

$E_2$  = dynamic modulus of elasticity of the gear

The different moduli of different materials for the pinion and gear have been taken into account.

For the mating components plastic/steel the corresponding factor for  $Z_M$  can be taken from Diagram 8.

For the mating components of gears made from the same plastic the following applies:

$$Z_{M(K/K)} = \frac{1}{\sqrt{2}} \cdot Z_{M(K/St)}$$

If the gear and pinion are made from different plastics, the factor  $Z_M$  (K/St) for the softer plastic should be used.

The tooth flank temperature is determined with the help of the formula in sections 3.2 or 3.2.1.

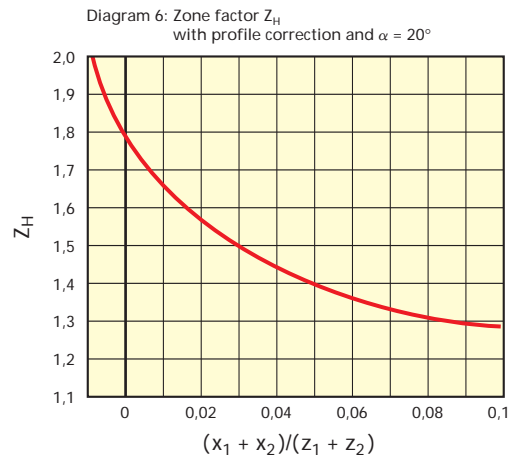

Diagram 7: Dynamic modulus of elasticity

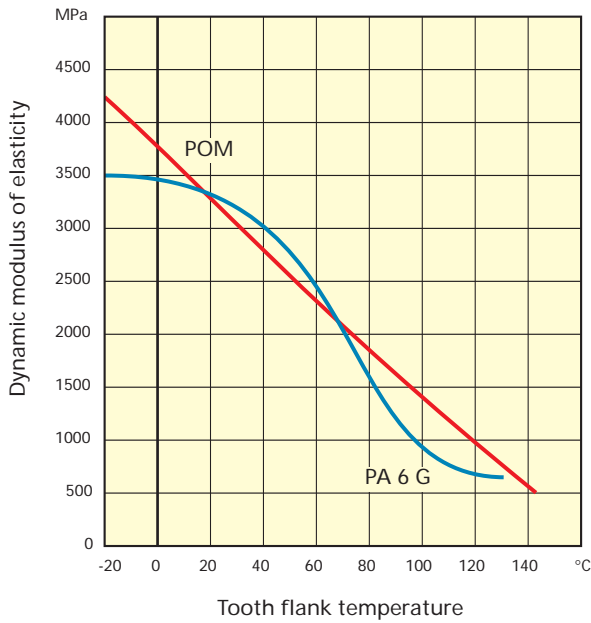
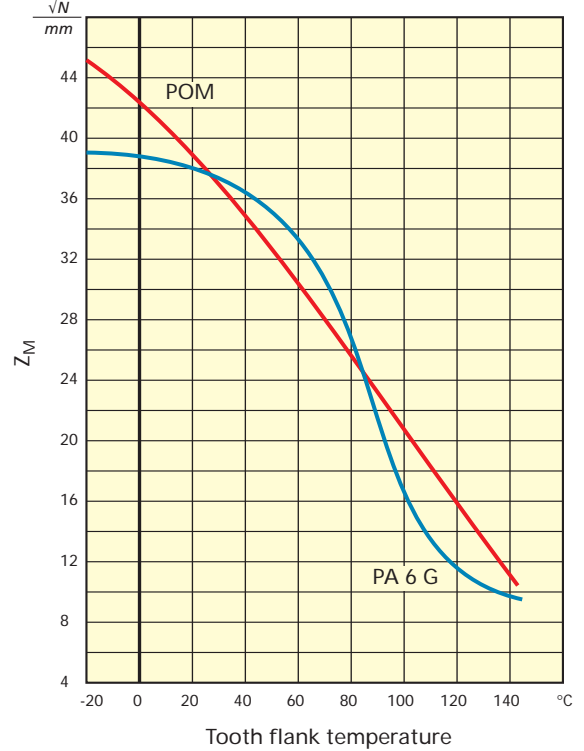

Diagram 8: Material factor for mating components K/St.



### 3.5 Safety factor S

The results for  $\sigma_F$  and  $\sigma_H$  from the calculations must be compared with the permissible values. As a rule a minimum safety factor of 1.2 to 2 is advisable. The following applies:

$$\sigma_{Fzul} = \frac{\sigma_{Fmax}}{S} \quad \text{and} \quad \sigma_{Hzul} = \frac{\sigma_{Hmax}}{S}$$

where

S = advisable safety factor

$\sigma_{Fmax}$  = permissible tooth root stress from Diagrams 9 and 10 in combination with the tooth temperature

or

S = advisable safety factor

$\sigma_{Hmax}$  = permissible flank pressure from Diagrams 11 to 14 in combination with the tooth temperature

The following table contains several minimum safety factors in relation to operating conditions.

Type of operation	Minimum safety factor
Normal operation	1,2
High stress reversal	1,4
Continuous operation with stress reversals $\geq 10^8$	$\geq 2$

The permissible tooth root stresses and flank pressures are shown in the following diagrams.

Diagram 9: Root strength of teeth  $\sigma_{Fmax}$  für POM

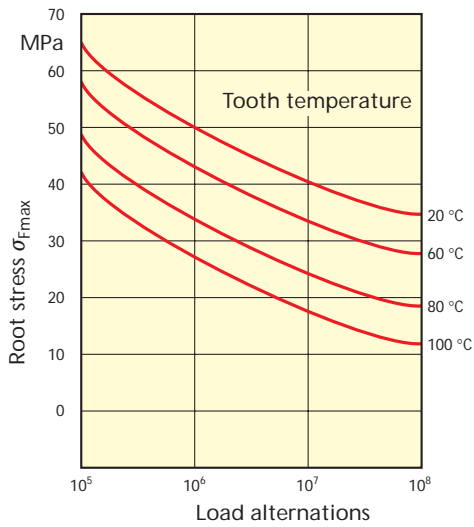

Diagram 10: Root strength of teeth  $\sigma_{Fmax}$  for PA 6 G

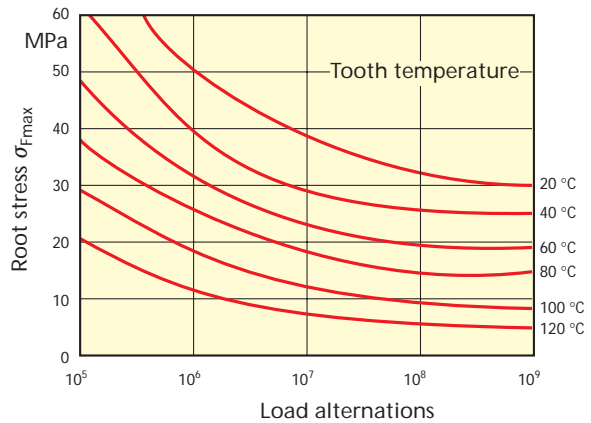

Diagram 11: Contact surface pressure  $\sigma_{Hmax}$  PA 6 G, dry running

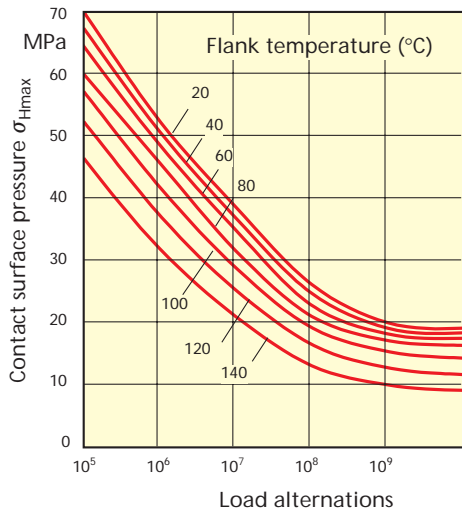

Diagram 12: Contact surface pressure  $\sigma_{Hmax}$  PA 6 G, grease lubrication

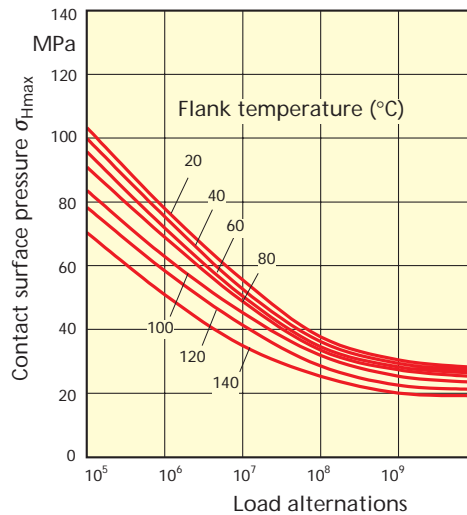

Diagram 13: Contact surface pressure  $\sigma_{Hmax}$  PA 6 G, oil lubrication

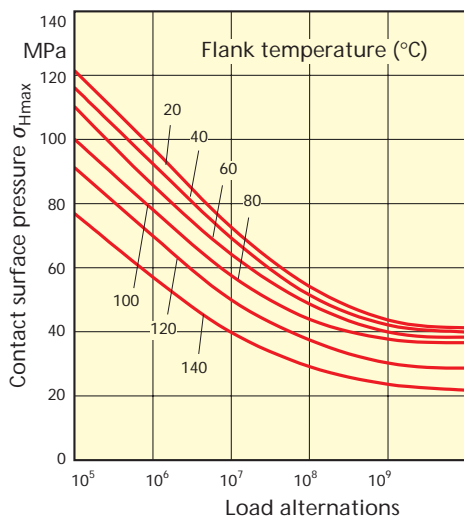
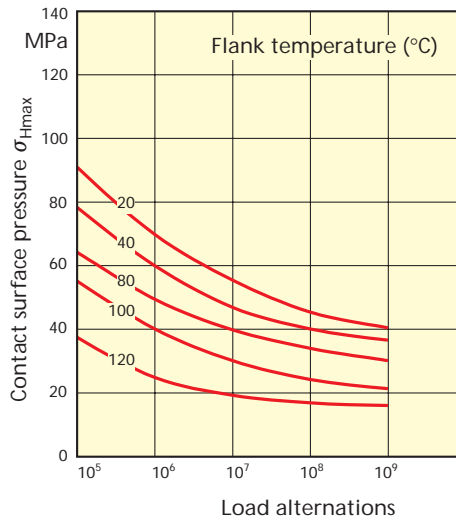

Diagram 14: Contact surface pressure  $\sigma_{Hmax}$  POM, dry running



### 3.6 Calculating tooth distortion

The tooth distortion that occurs when a load is applied acts like a pitch error during the transition from the loaded to the unloaded condition of the tooth. As excessive deformation could cause the gear to break down, plastic gears must be examined in regards to their compliance with the maximum permissible tooth distortion.

Tooth distortion  $f_K$  as a correction of the crest of the tooth in the peripheral direction becomes

$$f_K = \frac{3 \cdot F_U}{2 \cdot b \cdot \cos \alpha_0} \cdot \varphi \cdot \left( \frac{\psi_1}{E_1} + \frac{\psi_2}{E_2} \right) \quad [\text{mm}]$$

where

$\varphi_F$  = correction value from Diagram 15

$\psi_{1,2}$  = correction values from Diagram 16

$E_{1,2}$  = modulus of elasticity from Diagram 7

For the mating components plastic/steel the following applies:

$$\frac{\psi_{ST}}{E_{ST}} = 0$$

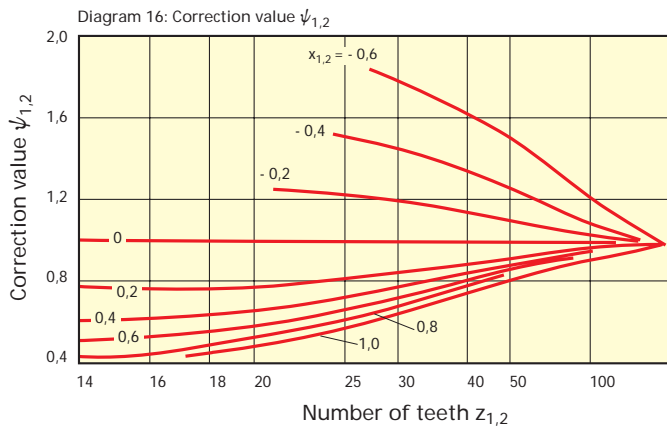
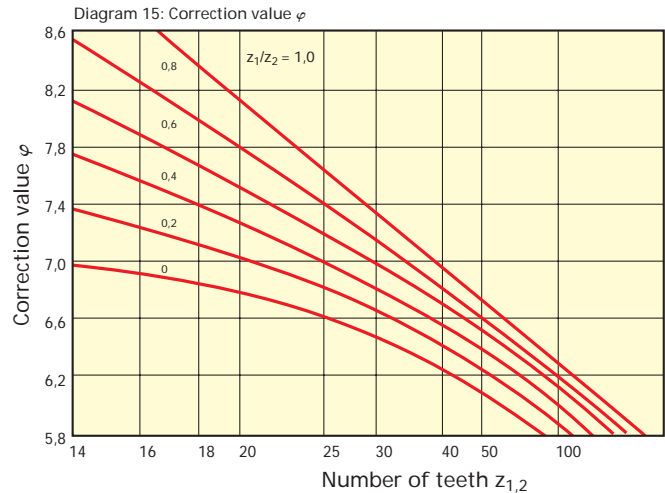

The permissible tooth distortion is generally determined by the requirements that are placed on the gears in regard to running noise and life. Practice has shown that the running noises increase considerably from a tooth distortion  $f_K = 0.4\text{mm}$ . Another parameter is the ratio between tooth distortion and module.

In the form of an equation, the permissible limiting values become

$$f_{Kzul} \leq 0,4 \quad [\text{mm}]$$

or

$$f_{Kper} \leq 0,1 \cdot m \quad [\text{mm}]$$

The calculated values should not exceed the limiting values. If, however, this is the case one would have to accept increased running noises and a shorter life.



**Our machining capabilities:**

- CNC milling machines, workpiece capacity up to max. 2000 x 1000mm
- 5-axis CNC milling machines
- CNC lathes, chucking capacity up to max. 1560 mm diameter and 2000 mm long
- Screw machine lathes up to 100mm diameter spindle swing
- CNC automatic lathes up to 100mm diameter spindle swing
- Gear cutting machines for gears starting at Module 0,5
- Profile milling (shaping and molding)
- Circular saws up to 170mm cutting thickness and 3100mm cutting length
- Four-sided planers up to 125mm thickness and 225mm width
- Thickness planers up to 230mm thickness and 1000mm width



**We process:**

- Polyamide
- Polyacetal
- Polyethylene terephthalate
- Polyethylene 1000
- Polyethylene 500
- Polyethylene 300
- Polypropylene
- Polyvinyl chloride (hard)
- Polyvinylidene fluoride
- Polytetrafluoroethylene
- Polyetheretherketone
- Polysulphone
- Polyether imide

- PA
- POM
- PET
- PE-UHMW
- PE-HMW
- PE-HD
- PP-H
- PVC-U
- PVDF
- PTFE
- PEEK
- PSU
- PEI

**Examples of parts:**

- Rope sheaves and castors
- Guide rollers
- Deflection sheaves
- Friction bearings
- Slider pads
- Guide rails
- Gear wheels
- Sprocket wheels
- Spindle nuts
- Curved feed tables
- Feed tables
- Feed screws
- Curved guides
- Metering disks
- Curved disks
- Threaded joints
- Seals
- Inspection glasses
- Valve seats
- Equipment casings
- Bobbins
- Vacuum rails/panels
- Stripper rails
- Punch supports

## Information on how to use this documentation

All calculations, designs and technical details are only intended as information and advice and do not replace tests by the users in regard to the suitability of the materials for specific applications. No legally binding assurance of properties and/or results from the calculations can be deduced from this document. The material parameters stated here are not binding minimum values, rather they should be regarded as guiding values. If not otherwise stated, they were determined with standardised samples at room temperature and 50% relative humidity. The user is responsible for the decision as to which material is used for which application and for the parts manufactured from the material. Hence, we recommend that practical tests are carried out to determine the suitability before producing any parts in series.

We expressly reserve the right to make changes to this document. Errors excepted.  
You can download the latest version containing all changes and supplements as a pdf file at [www.licharz.de](http://www.licharz.de).

© Copyright by Licharz GmbH, Germany

## Bibliography

The following literature was used to compile "Designing with plastics":

Ebeling, F.W. / Lüpke, G. Schelter, W. / Schwarz, O.	Kunststoffverarbeitung; Vogel Verlag
Biederbick, K.	Kunststoffe; Vogel Verlag
Carlowitz, B.	Kunststofftabellen; Hanser Verlag
Böge, A.	Das Techniker Handbuch; Vieweg Verlag
Ehrenstein, Gottfried W.	Mit Kunststoffen Konstruieren; Hanser Verlag
Strickle, E. / Erhard G.	Maschinenelemente aus thermoplastischen Kunststoffen Grundlagen und Verbindungselemente; VDI Verlag
Strickle, E. / Erhard G.	Maschinenelemente aus thermoplastischen Kunststoffen Lager und Antriebselemente; VDI Verlag
Erhard, G.	Konstruieren mit Kunststoffen; Hanser Verlag
Severin, D.	Die Besonderheiten von Rädern aus PolymerMaterialien; Specialist report, Berlin Technical University
Severin, D. / Liu, X.	Zum Rad-Schiene-System in der Fördertechnik, Specialist report, Berlin Technical University
Severin, D.	Teaching material Nr. 701, Pressungen
Liu, X.	Personal information
Becker, R.	Personal information
VDI 2545	Zahnräder aus thermoplastischen Kunststoffen; VDI Verlag
DIN 15061 Part 1	Groove profiles for wire rope sheaves; Beuth Verlag
DIN ISO 286	ISO coding system for tolerances and fits; Beuth Verlag
DIN ISO 2768 Part 1	General tolerances; Beuth Verlag
DIN ISO 2768 Part 2	General tolerances for features; Beuth Verlag

For further information, detailed catalogs are available:

- Information on Licharz machining capabilities of component parts
- Brochure „Material Guiding Values/chemical Resistance“
- Product information on semi-finished products of PA, POM und PET
- Delivery programme

Visit us on the internet at [www.licharz.de](http://www.licharz.de)



## Headquarters:

Licharz GmbH  
Industriepark Nord  
D-53567 Buchholz  
Germany

Telefon: ++49 (0) 26 83-977 0  
Telefax: ++49 (0) 26 83-977 111  
Internet: [www.licharz.de](http://www.licharz.de)  
E-Mail: [info@licharz.de](mailto:info@licharz.de)

## Branch offices:

Licharz Ltd.  
Daimler Close  
Royal Oak Industrial Estate  
Daventry, NN11 8QJ  
Great Britain  
Phone: ++44 (0) 1327 877 500  
Fax: ++44 (0) 1327 877 333  
Internet: [www.licharz.co.uk](http://www.licharz.co.uk)  
E-Mail: [sales@licharz.co.uk](mailto:sales@licharz.co.uk)

ZL Engineering Plastics  
PO Box 2270  
12 John Walsh Boulevard  
Peekskill, NY 10566  
USA  
Phone: ++1 914 – 736 6066  
Fax: ++1 914 – 736 2154  
E-Mail: [info@zlplastics.com](mailto:info@zlplastics.com)

ZL Engineering Plastics  
8485 Unit D  
Artesia Boulevard  
Buena Park, CA 90621  
USA  
Phone: ++1 714 – 523 0555  
Fax: ++1 714 – 523 4555  
E-Mail: [info@zlplastics.com](mailto:info@zlplastics.com)

