

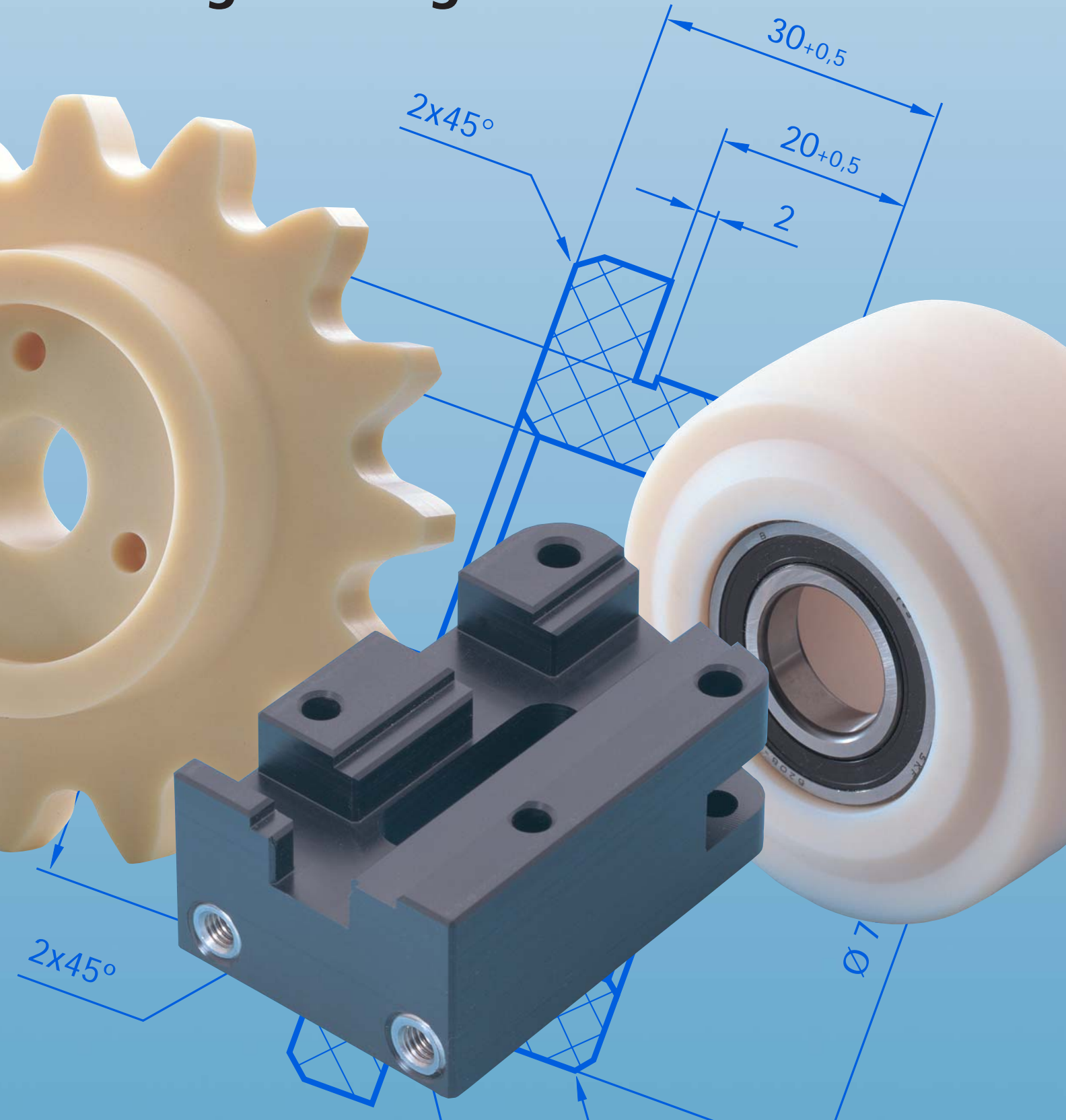

Designing with engineering Plastics

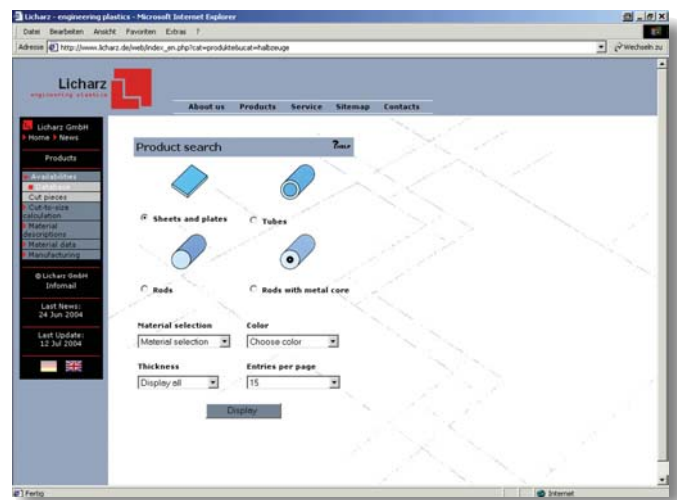

Licharz on the web



Plastic sheaves



1. Use of PA 6 G as a sheave material

Steel wire ropes are important and highly stressed machine elements in conveying technology. In many cases, large plants depend on their functioning not only for efficiency but also safety. As opposed to other machine elements, they must be replaced before they are completely damaged.

The surface pressure that occurs at the point of contact between the sheave and the rope is decisive for the service life and loadability of ropes that run over sheaves. Sheave materials with a low modulus of elasticity lead to low surface pressures and consequently to a longer service life of the rope. For this reason, thermoplastics are used to manufacture sheaves.

The plastics need to offer the following properties:

- Rope conserving elasticity
- Adequate compression fatigue strength
- High wear resistance
- Adequate toughness, also at low temperatures
- Resistance to lubricants
- High resistance to weathering effects

Experience has shown that cast polyamide (PA 6 G) fulfils these requirements more than adequately. Other plastics such as PE-UHMW or PVC as shock-resistant modifications are only used in special cases due to their low degree of loadability and lower wear resistance. Because of this, we will only deal with PA 6 G as a sheave material in the following.

1.1 Advantages of sheaves made from PA 6 G

1.1.1 Low rope wear

Ropes that run over sheaves made from metallic materials are subject to high stress due to the surface pressure that occurs between the rope and the groove. When the rope rolls over the sheave, only the outer strands lie on the groove. The result of this is wear in the form of individual strands breaking or, more serious, rope breakage.

Sheaves made from PA 6 G prevent this due to their elastic behaviour. The pressure between the rope and the roller in the combination steel rope/polyamide roller is around 1:10 compared to steel rope/steel roller. This can be attributed to the visco-elastic behaviour of polyamide. It is not just the outer strands that lie in the groove, but almost the whole projected strand width. This reduces surface pressure between the rope and the roller and considerably extends the life of the rope.

1.1.2 Weight reduction

Polyamides are around seven times lighter than steel. Because of the weight advantage, a considerable weight reduction can be achieved by using polyamide sheaves with a similar load bearing capacity. A mobile crane with up to 18 polyamide sheaves can save approx. 1,000kg and thus reduce the axle load. The lighter sheave weight also has a positive effect on the crane boom and considerably eases the handling and assembly of the sheaves.

1.1.3 Damping

The good damping properties of PA 6 G reduce vibration that metallic sheaves transfer from the rope via the sheave to the shaft and bearings. This conserves the rope, shaft and bearings and also reduces running noise.

1.2 Lubricating the rope

The use of viscous and adhesive rope lubricants can cause the rope to stick to the sheave groove. In combination with a dusty environment or dirt particles that are introduced to the sheave system, this forms an abrasive paste that can cause increased wear on the rope and the sheave. Therefore we recommend that the rope is lubricated with a low viscous corrosion protection oil, which keeps the rope and the sheave relatively clean.

1.3 Wear on sheaves made from PA 6 G

Essentially, wear is caused on polyamide sheaves through excess mechanical stress or wheel slip, whereby the sheave groove is the most stressed point. The sheave groove is subjected to pulsating stresses as the rope rolls over it and it becomes warm at high speeds.

Basically, wear on idler sheaves or sheaves that run over a taut rope is less than on driven sheaves. If stranded ropes are used, the individual strands can press into the base of the groove in highly stressed applications. For highly stressed, non-slipping sheaves in combination with an open stranded rope, the circumference of the groove base must not be an integral multiple of the wire strand. Thus, like the combing teeth of a cog wheel, it is prevented that the same points of the groove base are constantly in contact with a rope summit or valley. When closed ropes are used in combination with lubricants, pits can form, which are probably caused in the same way as pits form with gear wheels. As a rule, under normal environmental conditions and when the limit load values are not exceeded, one can expect groove base wear of $\leq 0.1 \mu\text{m}/\text{km}$.

2. Construction Design information

2.1 Sheave groove profile

The radius of the sheave groove should be approx. 5 – 10% larger than half the diameter of the rope. This ensures that rope tolerances are adequately considered and that the rope sits well in the groove.

The sheave groove depth h is given in DIN 15061 part 1 for steel sheaves as at least $h_{\text{min}} = d\sqrt{2}$.

We recommend a sheave groove depth of $h \geq 1.5d$ for polyamide sheaves.

The V angle β is dependent on the lateral fleet angle (max. permissible fleet angle in the groove direction = 4.0°).

The following groove angles in combination with the fleet angle have stood the test:

Fleet angle	$0^\circ - 2.5^\circ \Rightarrow \beta = 45^\circ$
Fleet angle	$>2.5^\circ - 4.0^\circ \Rightarrow \beta = 52^\circ$

A groove angle of $< 45^\circ$ should be avoided. DIN 15061 part 1 recommends the dimensions in Table 1 as guiding values for sheave groove profiles. As a guiding value for the diameter of the rope groove base of rope disks made from cast polyamide, we recommend:

$$D_1 = 22 \cdot d_1 \text{ [mm]}$$

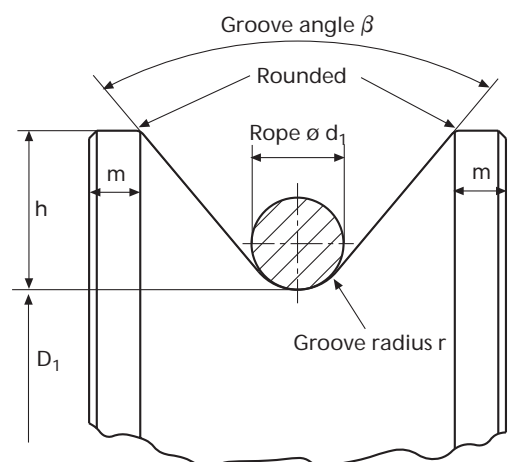

Table 1: Guiding values for rope groove profiles in mm according to DIN 15061 Part 1

$\varnothing d_1$	r_1	h	m	$\varnothing d_1$	r_1	h	m	$\varnothing d_1$	r_1	h	m
3	1,6	8	2	21	11	35	7	39	21	60	11
4	2,2	10	2	22	12	35	7	40	21	60	11
5	2,7	12,5	2	23	12,5	35	7	41	23	60	11
6	3,2	12,5	3	24	13	37,5	8	42	23	65	11
7	3,7	15	4	25	13,5	40	8	43	23	65	11
8	4,2	15	4	26	14	40	8	44	24	65	12,5
9	4,8	17,5	4,5	27	15	40	8	45	24	65	12,5
10	5,3	17,5	4,5	28	15	40	8	46	25	67,5	12,5
11	6,0	20	5	29	16	45	8	47	25	70	12,5
12	6,5	20	5	30	16	45	8	48	26	70	12,5
13	7,0	22,5	5	31	17	45	8	49	26	72,5	12,5
14	7,5	25	6	32	17	45	8	50	27	72,5	12,5
15	8,0	25	6	33	18	50	10	52	28	75	12,5
16	8,5	27,5	6	34	19	50	10	54	29	77,5	12,5
17	9,0	30	6	35	19	55	10	56	30	80	12,5
18	9,5	30	6	36	19	55	10	58	31	82,5	12,5
19	10,0	32,5	7	37	20	55	11	60	32	85	12,5
20	10,5	35	7	38	20	55	11	-	-	-	-

2.2 Bearings

Due to the good sliding properties of PA 6 G, when sheaves are not subjected to undue stress, friction bearings can be used. Decisive is the pv limiting value. If high degrees of wear are expected on the bearing with an intact sheave groove, the use of a replaceable bearing bush can prevent the sheave having to be replaced prematurely.

For highly stressed sheaves, whose maximum load values are above those for a friction bearing, we recommend the installation of anti-friction bearings. These can be mounted by pressing them into a bearing seat produced according to the dimensions in Diagrams 1 and 2. If axial loads are expected on the anti-friction bearings, we recommend that the bearing is secured against falling out by securing elements commonly used in machine engineering, such as circlips according to DIN 472.

The following diagram shows several possible sheave designs.

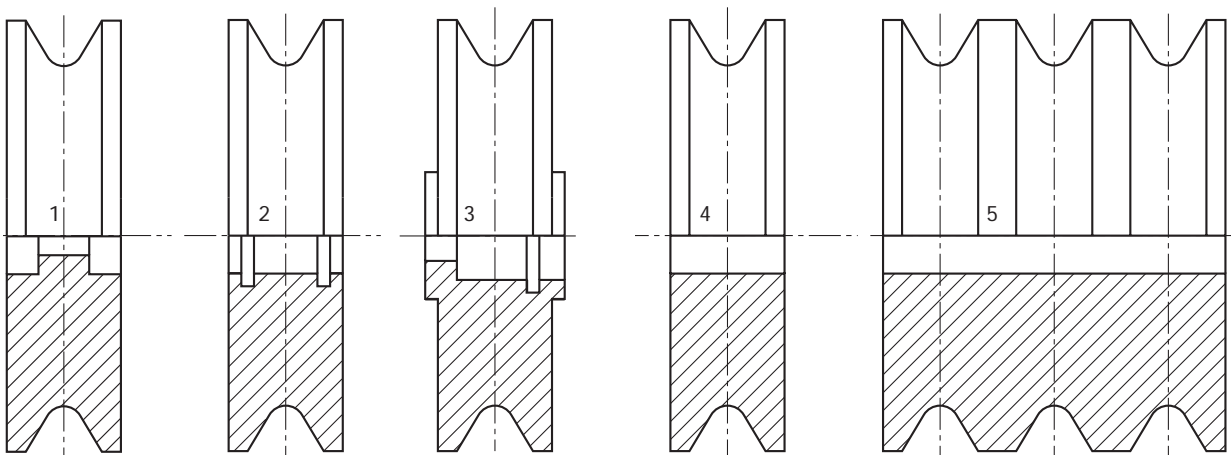

Design with bearing seat for antifriction bearings

Design with friction bearings

Diagram 1: Recommended bore setting size for antifriction bearing seats

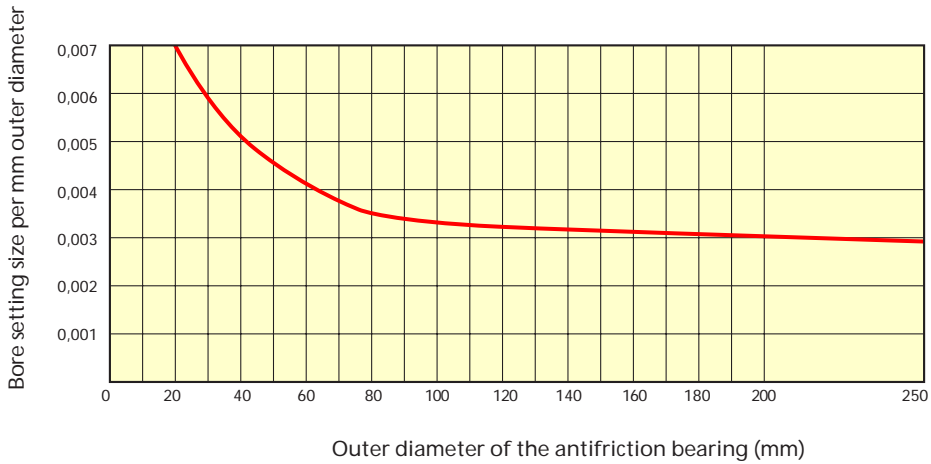
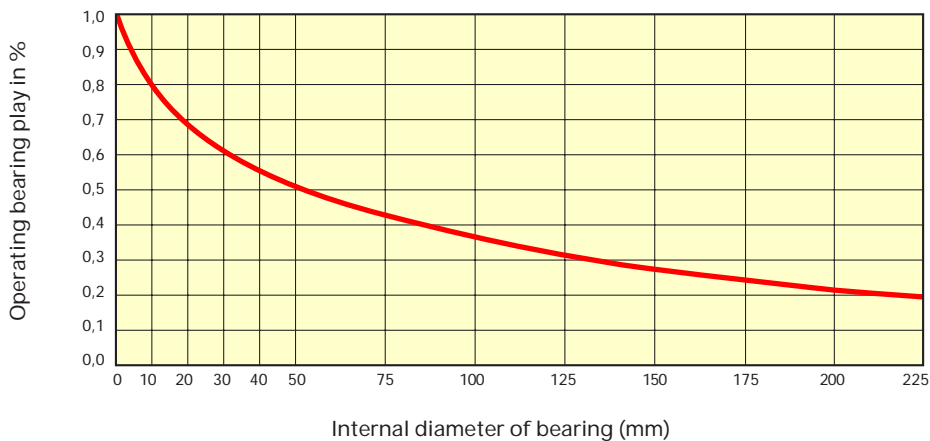

Diagram 2: Recommended operating bearing play for friction bearings



When calculating and dimensioning the bearings, especially friction bearings, attention should be paid that the bearing load for idler sheaves corresponds to the rope tension, but for fixed sheaves the angle of contact forms a force equal to twice the cable tension at 180°. Section 3 »Calculating sheaves« provides more information on this subject.

3. Calculating rope pulleys sheaves

For the calculation of sheaves, distinctions must be made regarding the load case, the rope used and the type of operation.

A distinction is made between

- Point loading on the sheave (the sheave runs on a taut rope)
- Circumferential loading on the sheave (rope encircles the sheave)

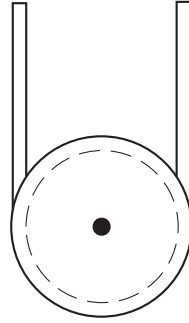
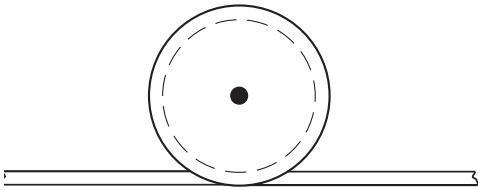

- The type of rope
Open wire rope (stranded rope)
Closed wire rope
- The type of operation
Loose sheave (e.g. sheave on a cableway)
Fixed sheave (e.g. deflection sheaves)

These criteria lead to different calculation procedures and force considerations for the individual load cases, rope types and types of operation.

3.1 Calculating the bearing compression

If the roller bearing is to be executed as a friction bearing, the pv values in the bearing must be calculated and compared with the permissible values for PA 6 G. The friction bearing should be considered in the same way as a press fit bearing bush. In other words, the calculation is the same as for dynamically loaded friction bearings. The expected bearing load is dependent on the type of operation of the sheave. For idler sheaves, the rope tension F_S can be used as the bearing load to calculate the pv value of the rope tension.

Thus the average surface pressure for radial bearings in idler sheaves is

$$p = \frac{F_S}{d_w \cdot L} \quad [\text{MPa}]$$

where

- F_S = rope tension in N
- d_w = shaft diameter in mm
- L = bearing width in mm

and the average sliding speed is

$$v = \frac{d_w \cdot \pi \cdot n}{60000} \quad [\text{m/s}]$$

where

- d_w = shaft diameter in mm
- n = speed in min^{-1}

Aggregated pv_{duration} for idler sheaves with dynamic loading becomes

$$pv_{\text{duration}} = \left(\frac{F_s}{d_w \cdot L} \right) \cdot \left(\frac{d_w \cdot \pi \cdot n}{60000} \right) \quad [\text{MPa} \cdot \text{m/s}]$$

In intermittent operation it is possible to correct pv_{duration} by the process described in the section 3.2 of the chapter on »Friction bearings«.

For fixed rollers, the bearing load is dependent on the angle of contact that the rope forms with the sheave. If the sheave is completely encircled (180°), the rope tension is doubled in the calculations. For an angle of contact $\alpha < 180^\circ$, a resulting force F_{res} must be calculated with the help of the angle and the cable tension.

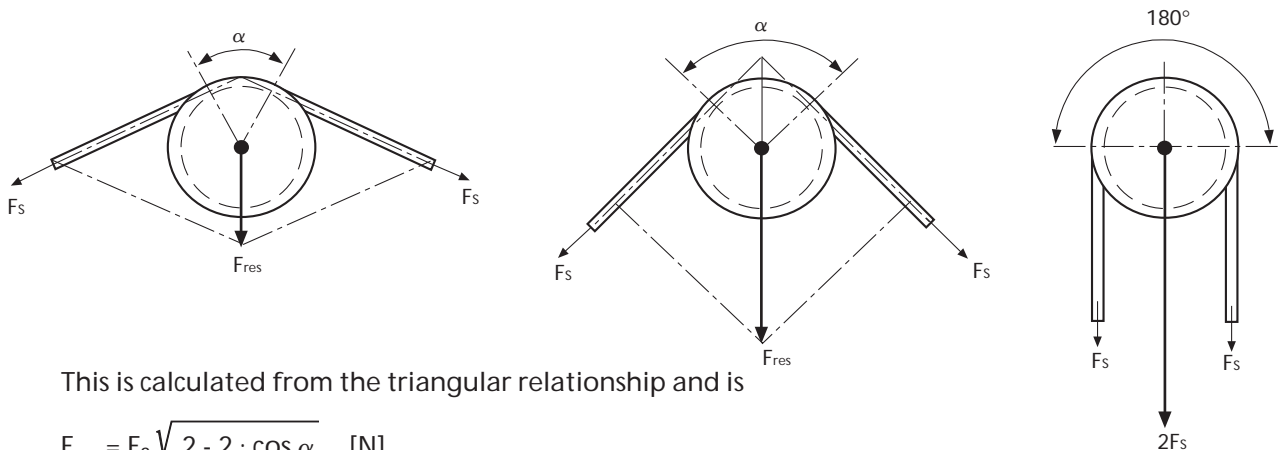

This is calculated from the triangular relationship and is

$$F_{\text{res}} = F_s \sqrt{2 - 2 \cdot \cos \alpha} \quad [\text{N}]$$

where

F_s = cable tension in N

α = angle of contact

For sheaves made from PA 6 G, the determined pv values may not exceed $0.13 \text{ Mpa} \cdot \text{m/s}$ in dry running applications or $0.5 \text{ Mpa} \cdot \text{m/s}$ with lubrication. If the calculated values exceed these maximum values, an antifriction bearing would be advisable.

3.2 Calculating the compression between the rope and the sheave groove

The main criterion for the load bearing capacity of sheaves is the compression between the rope and the sheave. To calculate the compression, the Hertz' equations that have been modified for this case are used. The results of the calculations must be compared with the permissible values for PA 6 G shown in Diagrams 3 and 4. They must be considered in combination with the speed of the rope and may not exceed these values.

3.2.1 Point contact of closed wire ropes

If closed wire ropes with a small fleet angle are used ($\alpha < 10^\circ$), such as is the case with cableways, this causes concentrated loading. The area of pressure is elliptical.

Under these conditions the compression parameter p' for sheaves made from PA 6 G is calculated from the equation

$$p' = \frac{63,5}{\xi \cdot \eta} \cdot \sqrt[3]{\left(\sum \frac{1}{R}\right)^2 \cdot F} \quad [\text{MPa}]$$

where

ξ = correction value

η = Hcorrection value

$\sum \frac{1}{R}$ = total of the principle curvatures in mm^{-1}

F = sheave load in N

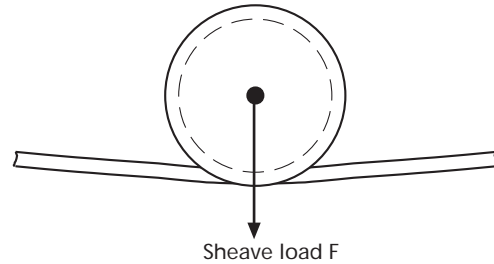

The sum of the principle curvatures of the bodies that are in contact with one another is calculated from

$$\sum \frac{1}{R} = \frac{2}{d} - \frac{1}{\rho} - \frac{1}{r} + \frac{2}{D} \quad [\text{mm}^{-1}]$$

From the sum of the principle curvatures, the correction angle ϑ can be used to determine the correction values ξ and η according to the following formula:

$$\cos \vartheta = \frac{\frac{2}{d} + \frac{1}{\rho} - \frac{1}{r} - \frac{2}{D}}{\sum \frac{1}{R}}$$

where

d = rope diameter in mm

ρ = rope curvature radius (generally negligible as it is very large compared to other radii)

r = groove radius in mm

D = groove base diameter

The correction values ξ and η can be found in Table 1. If ϑ lies between the table values, the correction values must be interpolated.

Table 1: Correction values ξ and η for different values of ϑ										
ϑ	90°	80°	70°	60°	50°	40°	30°	20°	10°	0°
ξ	1,0	1,128	1,284	1,486	1,754	2,136	2,731	3,778	6,612	∞
η	1,0	0,893	0,802	0,717	0,641	0,567	0,493	0,408	0,319	0

3.2.2 Point contact of open wire ropes

It can be assumed for sheaves made from PA 6 G that because of the elasticity of the sheave in combination with an open stranded rope, that not one single wire from the strand lies in the groove but rather several wires and that these participate in the transmission of power. Therefore, the entire strand is regarded as a single wire and it is assumed that all loaded strands transmit the same power. In the calculation, a correcting factor is introduced that takes account of the power transmission of several strands (maximum 40%).

With this consideration the compression parameter p' becomes

$$p' = p'_e \cdot \sqrt[3]{\frac{X}{Z}} \quad [\text{MPa}]$$

and the compression parameter p'_e for one single wire in combination with a PA 6 G sheave is

$$p'_e = 42 \cdot \sqrt[3]{\left(1 - \frac{d_1}{2r} + \frac{d_1}{D}\right)^2 \cdot \frac{F}{d_1^2}} \quad [\text{MPa}]$$

where

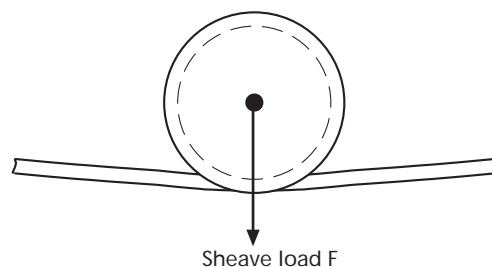

- X = correction factor in relation to p'_e , from Table 2
- Z = number of outer strands
- d_1 = strand diameter in mm
- r = groove radius in mm
- D = groove base diameter in mm
- F = sheave load in N

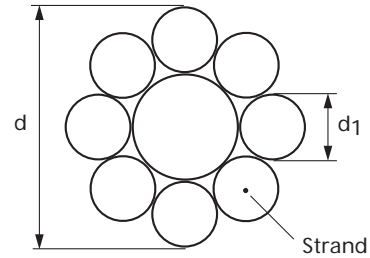

3.2.3 Peripheral load with open wire ropes

In regard to the power transmission between the rope and the sheave, the same applies as to concentrated loading as described in item 3.2.2. The only difference is that the load on a completely encircled pulley is not a point load but a uniform load.

Hence, the compression parameter p' becomes

$$p' = p'_e \cdot \sqrt{\frac{X}{Z}} \quad [\text{MPa}]$$

and the compression parameter p'_e for a single wire in combination with a PA 6 G sheave is

$$p'_e = 55 \cdot \sqrt{\frac{(2r - d_1) \cdot F_s}{2r \cdot d_1 \cdot D}} \quad [\text{MPa}]$$

- X = correction factor in relation to p'_e , from Table 2
- Z = number of outer strands
- d_1 = strand diameter in mm
- r = groove radius in mm
- D = groove base diameter in mm
- F_s = cable tension in N

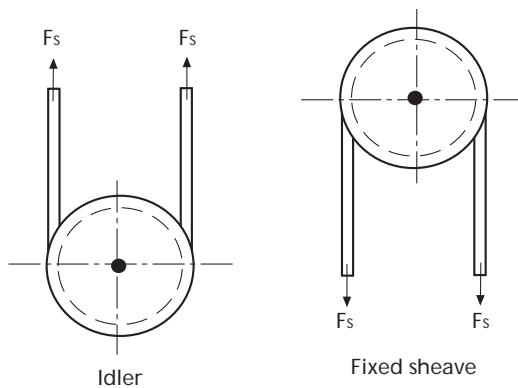

When determining the correction factor, it should be considered that when $X > Z$, $Z = X$ must be inserted in the radicand of the correction factor so that the radicand is 1. If the value of p'_e is between the values given in the table, the value for X must be interpolated accordingly.

Table 2: Correction factor X

Surface pressure p'_e in MPa	Correction factor X
≤ 50	Z
150	6
300	4
≥ 450	2,5

3.3 Maximum permissible surface pressures

The results from the calculations must be compared with the maximum permissible load parameters from Diagrams 3 and 4. It is not permissible to exceed these values.

Diagram 3: Load limit in relation to the rope speed and ambient temperature for sheaves made from PA 6 G under peripheral loading

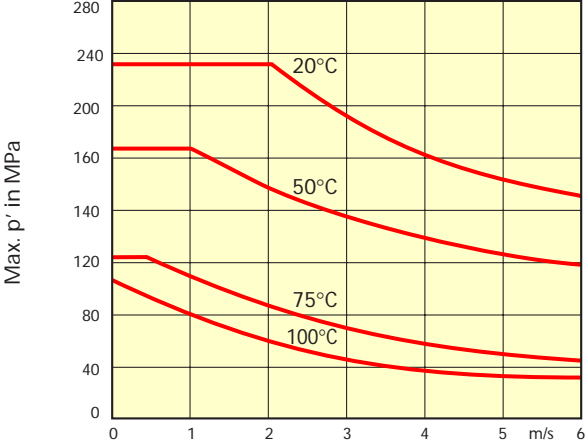
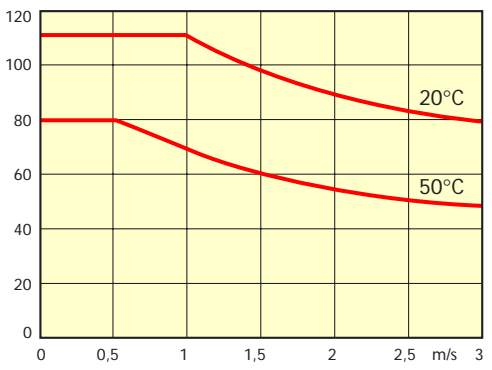

Diagram 4: Load limit parameter p'max in relation to the rope speed and ambient temperature for sheaves made from PA 6 G under concentrated loading.





Our machining capabilities:

- CNC milling machines, workpiece capacity up to max. 2000 x 1000mm
- 5-axis CNC milling machines
- CNC lathes, chucking capacity up to max. 1560 mm diameter and 2000 mm long
- Screw machine lathes up to 100mm diameter spindle swing
- CNC automatic lathes up to 100mm diameter spindle swing
- Gear cutting machines for gears starting at Module 0,5
- Profile milling (shaping and molding)
- Circular saws up to 170mm cutting thickness and 3100mm cutting length
- Four-sided planers up to 125mm thickness and 225mm width
- Thickness planers up to 230mm thickness and 1000mm width

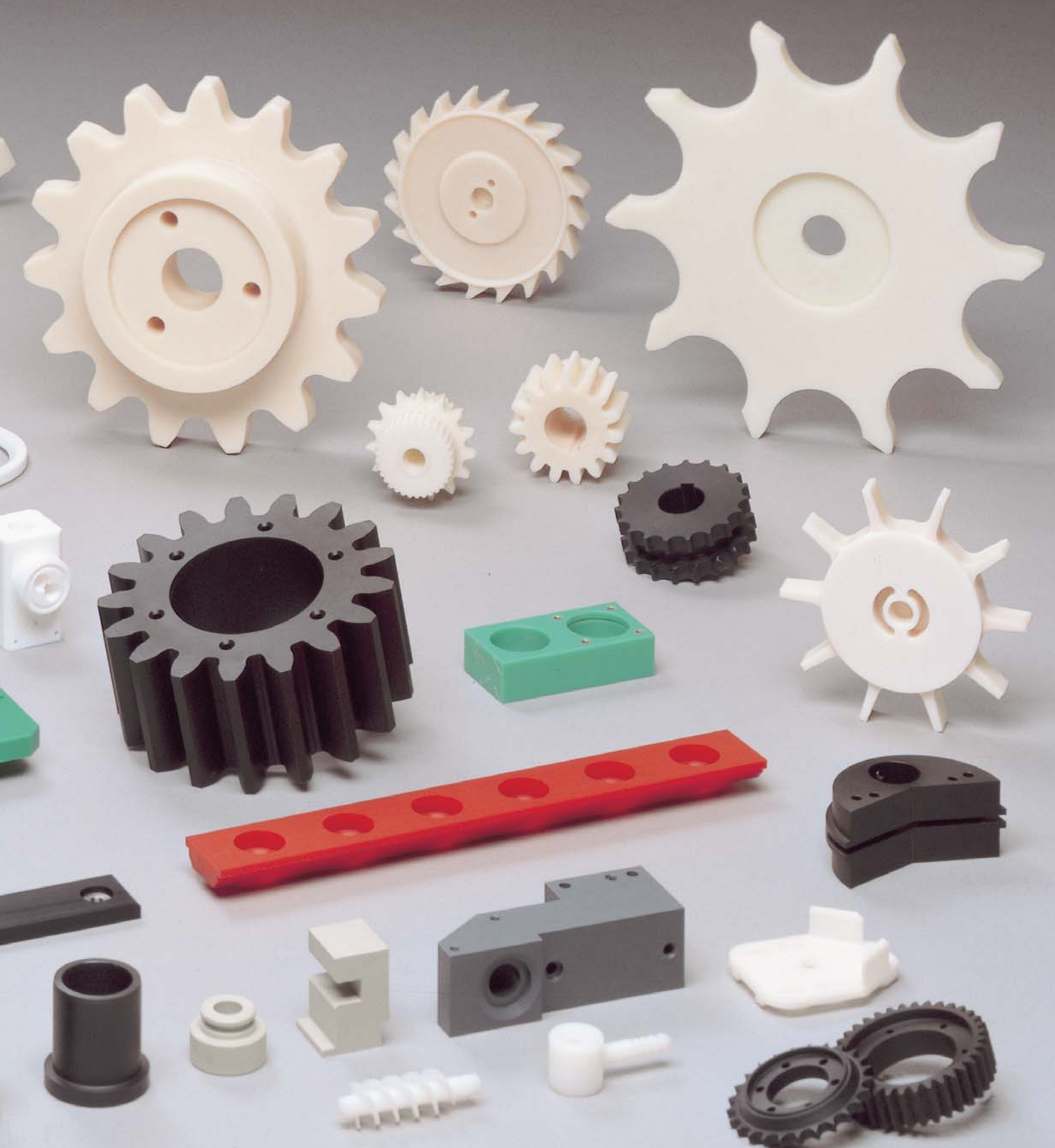

We process:

- Polyamide
- Polyacetal
- Polyethylene terephthalate
- Polyethylene 1000
- Polyethylene 500
- Polyethylene 300
- Polypropylene
- Polyvinyl chloride (hard)
- Polyvinylidene fluoride
- Polytetrafluoroethylene
- Polyetheretherketone
- Polysulphone
- Polyether imide

- PA
- POM
- PET
- PE-UHMW
- PE-HMW
- PE-HD
- PP-H
- PVC-U
- PVDF
- PTFE
- PEEK
- PSU
- PEI

Examples of parts:

- Rope sheaves and castors
- Guide rollers
- Deflection sheaves
- Friction bearings
- Slider pads
- Guide rails
- Gear wheels
- Sprocket wheels
- Spindle nuts
- Curved feed tables
- Feed tables
- Feed screws
- Curved guides
- Metering disks
- Curved disks
- Threaded joints
- Seals
- Inspection glasses
- Valve seats
- Equipment casings
- Bobbins
- Vacuum rails/panels
- Stripper rails
- Punch supports

Information on how to use this documentation

All calculations, designs and technical details are only intended as information and advice and do not replace tests by the users in regard to the suitability of the materials for specific applications. No legally binding assurance of properties and/or results from the calculations can be deduced from this document. The material parameters stated here are not binding minimum values, rather they should be regarded as guiding values. If not otherwise stated, they were determined with standardised samples at room temperature and 50% relative humidity. The user is responsible for the decision as to which material is used for which application and for the parts manufactured from the material. Hence, we recommend that practical tests are carried out to determine the suitability before producing any parts in series.

We expressly reserve the right to make changes to this document. Errors excepted.
You can download the latest version containing all changes and supplements as a pdf file at www.licharz.de.

© Copyright by Licharz GmbH, Germany

Bibliography

The following literature was used to compile "Designing with plastics":

Ebeling, F.W. / Lüpke, G. Schelter, W. / Schwarz, O.	Kunststoffverarbeitung; Vogel Verlag
Biederbick, K.	Kunststoffe; Vogel Verlag
Carlowitz, B.	Kunststofftabellen; Hanser Verlag
Böge, A.	Das Techniker Handbuch; Vieweg Verlag
Ehrenstein, Gottfried W.	Mit Kunststoffen Konstruieren; Hanser Verlag
Strickle, E. / Erhard G.	Maschinenelemente aus thermoplastischen Kunststoffen Grundlagen und Verbindungselemente; VDI Verlag
Strickle, E. / Erhard G.	Maschinenelemente aus thermoplastischen Kunststoffen Lager und Antriebselemente; VDI Verlag
Erhard, G.	Konstruieren mit Kunststoffen; Hanser Verlag
Severin, D.	Die Besonderheiten von Rädern aus PolymerMaterialien; Specialist report, Berlin Technical University
Severin, D. / Liu, X.	Zum Rad-Schiene-System in der Fördertechnik, Specialist report, Berlin Technical University
Severin, D.	Teaching material Nr. 701, Pressungen
Liu, X.	Personal information
Becker, R.	Personal information
VDI 2545	Zahnräder aus thermoplastischen Kunststoffen; VDI Verlag
DIN 15061 Part 1	Groove profiles for wire rope sheaves; Beuth Verlag
DIN ISO 286	ISO coding system for tolerances and fits; Beuth Verlag
DIN ISO 2768 Part 1	General tolerances; Beuth Verlag
DIN ISO 2768 Part 2	General tolerances for features; Beuth Verlag

For further information, detailed catalogs are available:

- Information on Licharz machining capabilities of component parts
- Brochure „Material Guiding Values/chemical Resistance“
- Product information on semi-finished products of PA, POM und PET
- Delivery programme

Visit us on the internet at www.licharz.de



Headquarters:

Licharz GmbH
Industriepark Nord
D-53567 Buchholz
Germany

Telefon: ++49 (0) 26 83-977 0
Telefax: ++49 (0) 26 83-977 111
Internet: www.licharz.de
E-Mail: info@licharz.de



Branch offices:

Licharz Ltd.
Daimler Close
Royal Oak Industrial Estate
Daventry, NN11 8QJ
Great Britain
Phone: ++44 (0) 1327 877 500
Fax: ++44 (0) 1327 877 333
Internet: www.licharz.co.uk
E-Mail: sales@licharz.co.uk

ZL Engineering Plastics
PO Box 2270
12 John Walsh Boulevard
Peekskill, NY 10566
USA
Phone: ++1 914 – 736 6066
Fax: ++1 914 – 736 2154
E-Mail: info@zlplastics.com

ZL Engineering Plastics
8485 Unit D
Artesia Boulevard
Buena Park, CA 90621
USA
Phone: ++1 714 – 523 0555
Fax: ++1 714 – 523 4555
E-Mail: info@zlplastics.com